

Standard Test Methods for Thickness and Density of Blanket or Batt Thermal Insulations¹

This standard is issued under the fixed designation C 167; the number immediately following the designation indicates the year of original adoption or, in the case of revision, the year of last revision. A number in parentheses indicates the year of last reapproval. A superscript epsilon (ϵ) indicates an editorial change since the last revision or reapproval.

This standard has been approved for use by agencies of the Department of Defense.

1. Scope

1.1 These test methods cover the determination of thickness and density of flexible, felted, or woven thermal insulating blankets, rolls, or batts composed of fibrous materials, with or without surface covering or reinforcement.

1.2 *This standard does not purport to address all of the safety concerns, if any, associated with its use. It is the responsibility of the user of this standard to establish appropriate safety and health practices and determine the applicability of regulatory limitations prior to use.*

2. Referenced Documents

- 2.1 *ASTM Standards:*
C 168 Terminology Relating to Thermal Insulation²

3. Terminology

3.1 *Definitions*—Terminology C 168 shall be considered as applicable to the terms used in these test methods.

4. Significance and Use

4.1 Proper measurements of thickness and density of blanket or batt insulations are essential for determining thermal insulation properties. For a particular batt or blanket product, thickness and density are usually directly related to thermal insulating value.

4.2 These test methods are of significant value in manufacturing quality control, to ensure that claimed insulation values of products are maintained.

5. Apparatus

5.1 *Depth Gage*, of the type shown in Fig. 1. The disk shall be fabricated of a suitable clear plastic material, so that the operator can see when contact is made with the insulation. The disk shall be perpendicular to the pin at all times and shall have

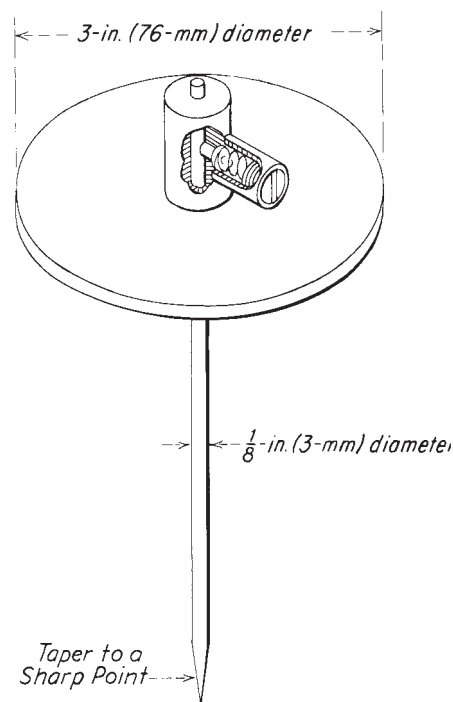

FIG. 1 Depth Gage for Thickness Measurements

a friction device to grip the pin unless purposely moved. The pin shall be of sufficient length for the material to be measured.

5.2 *Steel rule*, graduated in 0.05-in. or 1-mm intervals.

5.3 *Scales*, of sufficient capacity and sensitivity to weigh the test specimen to an accuracy of $\pm 0.5\%$.

6. Sampling

6.1 A test sample shall consist of one representative roll or bundle of insulation.

6.2 *Sampling of Bundles*—For bundles which contain 20 or more batts, five batts shall be selected. Otherwise, either the three-batt or five-batt selection technique may be used. Batt which are folded in half shall count as two batts for purposes of choosing and employing the selection method.

6.2.1 *Three-Batt Method*—Select the center batt and the second batt in from each end of the package.

¹ These test methods are under the jurisdiction of ASTM Committee C16 on Thermal Insulation and are the direct responsibility of Subcommittee C16.32 on Mechanical Properties.

Current edition approved April 10, 2003. Published July 2003. Originally approved in 1941. Last previous edition approved in 1998 as C 167 – 98.

² *Annual Book of ASTM Standards*, Vol 04.06.

6.2.2 *Five-Batt Method*—Divide the package sequentially into five groups of batts as equal in number as possible. Select the first batt from each group. Be careful to select one and only one batt from the two end batts within the package.

6.2.3 Cut batts which are longer than 48 in. to 48 ± 0.25 in. (122 ± 0.63 cm) in length.

6.3 *Sampling of Cut Rolls*—Five batts will be cut of roll-width by 48 ± 0.25 in. (122 ± 0.63 cm) in length.

6.3.1 Cut one batt from the center of the roll, two batts from the ends of the roll, and the fourth and fifth from the quarter points along the length.

6.3.2 For blankets wider than 24 in., cut each of the five batts 24 ± 0.25 in. (61 ± 0.63 cm) wide by 48 ± 0.25 in. (122 ± 0.63 cm) long.

6.4 *Sampling for Full Roll Method*—This method can be used in place of 6.3 when the roll is wider than 24 in. (61 cm) or longer than 50 ft (16.4 m). Prior to unrolling the material, weigh the entire roll to the nearest 0.25 pound (0.11 kg). Two methods may be used to obtain the full roll weight. The first method removes the insulation product from the packaging prior to weighing. The material will expand and may unroll slightly, care must be taken to ensure that the full roll is weighed accurately. The second method weighs the packaged insulation product, then weighs the packaging material only. The packaging material weight is subtracted from packaged product weight to obtain net material weight.

7. Procedure

7.1 *Expansion of Bundles and Cut Roll*—Hold the first batt vertically off the floor by grasping it with both hands on its long dimension so that the lower edge is 18 ± 1 in. (460 ± 25 mm) above the floor. Release the batt, allowing it to strike the floor. Repeat the above for a second time. Next, holding the batt by the other long edge, drop twice as above. Place the specimen on a flat, hard surface. Repeat the above for the remaining four specimens. Allow specimens to reach equilibrium by waiting at least 5 min before making thickness measurements within 1 in. (25 mm) in any direction of five points as indicated in Fig. 2.

NOTE 1—If 23-in. (580-mm) wide samples are tested, use a quarter or half of that dimension to establish the test points.

NOTE 2—Some materials may require 4 h or more to reach equilibrium.

7.2 *Expansion of Full Roll*—Unroll the insulation. Flip the test roll over its entire length so the bottom surface is now on top. Next grasp one end and pull the material over itself until the original surface is again facing up. If there is insufficient room to pull the material over itself (less than twice the unrolled length), the material may be repositioned by sliding

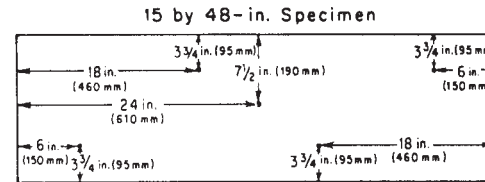
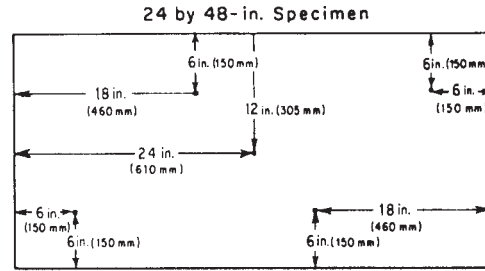

FIG. 2 Thickness Measurement Locations

the partially pulled roll to the end of the testing space, and continue to pull the material over itself.

NOTE 3—Use 7.1 if sampling procedure in 6.3 is used.

7.3 *Measurement of Bundles and Cut Roll*—Insert the pin of the thickness gage vertically into the material at the first measuring point with a twisting motion until it contacts the hard surface beneath. Lower the disk until it lightly and uniformly contacts the specimen. An alternative procedure is to use a disk whose mass exerts a specified pressure of at least 0.4 lbf/ft² (20 Pa) on the specimen. With the gage disk locked against the pin, lift the gage unit from the test specimen. While holding the gage in locked position, place the disk against the zero end of the rule with the pin projecting along the calibrated surface of the rule. Observe and record the reading at the pointed end of the pin to the nearest 0.05 in. (1 mm). Repeat the above for each of the remaining measuring points as shown in Fig. 2.

7.4 *Measurement of Full Roll*—Record the roll length to the nearest 1 in. (2.54) cm. Take measurements on each side of the roll. If the roll has been cut in half, take a third roll length measurement along the midpoint of the roll width. Record roll width at three locations to the nearest 0.125 in. (0.32 cm). Width measurements will be taken 10 ft (3.05 m) from each end, and in the middle of the roll length. Using a pin gage, record thickness to the nearest 0.05 in. (1 mm) as shown in Fig.

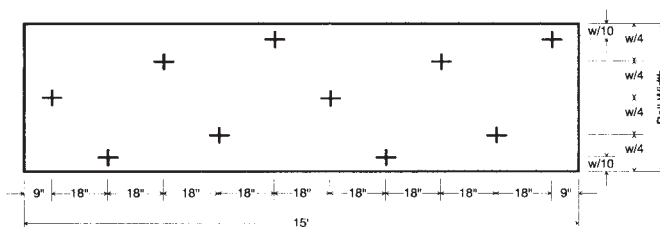

FIG. 3 Thickness Measurement Locations – Full Roll

3. Refer to Section 7.3 for use of pin gauge. Two 15 ft (4.57 m) long sections shall be measured. These sections shall be 10 (3.05 m) in from each end. A total of twenty thickness measurements will be taken for each roll.

NOTE 4—Use 7.4 if sampling procedure in 6.4 is used.

8. Calculation

8.1 *Thickness*—Take the average of the thickness measurements made in accordance with Section 7 as the thickness of the specimen.

8.2 *Area Weight and Density*—Calculate the weight per unit area and the density by one of the following equations:

$$\text{Weight per unit area as received, lb/ft}^2 \text{ (or kg/m}^2\text{)} = w_1/(L \times W) \quad (1)$$

$$\text{Weight per unit area without facings, lb/ft}^2 \text{ (or kg/m}^2\text{)}$$

$$= w_2/(L \times W)$$

$$\text{Density of insulation (without facings), lb/ft}^3 \text{ (or kg/m}^3\text{)}$$

$$= w_2/(L \times W \times T)$$

$$\text{Density of insulation (without facings) at specified thickness, lb/ft}^3$$

$$\text{(or kg/m}^3\text{)}$$

$$= (w_2)/(L \times W \times \text{specified thickness})$$

where:

w_1 = total weight of test specimen, lb (or kg),

w_2 = weight of test specimen without facings, lb (or kg),

L = length of test specimen, ft (or m),

W = width of test specimen, ft (or m),

T = thickness of test specimen, converted from in. to ft (or mm to m), and

specified thickness = ordered thickness, ft (or m).

9. Report

9.1 Report the following information:

9.1.1 The pressure exerted on the test specimens during thickness measurements, if the gage used is of the type that exerts a pressure,

9.1.2 Average, maximum, and minimum of the measured values of thickness of the test specimen, expressed in inches (or millimetres),

9.1.3 Weight per unit area as received, expressed in pounds per square foot (or kilograms per square metre),

9.1.4 Density of insulation, expressed in pounds per cubic foot (or kilograms per cubic metre), and

9.1.5 Age of material when tested, if known, and description of package (roll, bag, etc.).

10. Precision and Bias ³

10.1 The precision and bias of these test methods depend on the ability to read and interpolate the steel rule and balance and to judge when surface contact occurs between the depth gage disk and the test specimen.

10.2 *Thickness of Bundles*—An interlaboratory comparison of six participating laboratories was conducted in 1991 on fibrous glass insulation. This test program used four common batt insulations and tested all batts within each package. A within-laboratory repeatability for thickness measurements of 7 % was obtained, which also includes product and packaging variability. Individual batt measurements were initially expressed as percentages of the average measurement of the respective package average. These percentages were then normalized to the average thickness versus piece location distribution for the respective product as measured by the six laboratories. Twice the sample standard deviation of these values yielded the repeatability. The 95 % repeatability limit, 2.8 (s_r), was 9 %.

10.3 The interlaboratory comparison noted in 10.2 yielded values for bias of the batt sampling techniques specified in 6.2 of not greater than 1 % for any of the products tested. Bias was measured in terms of the percent deviation of the average thickness of the sampled batts from the package average.

10.4 Imprecision of the batt sampling techniques was determined to be 2.4 % for the five-batt method and 3.6 % for the three-batt method.

NOTE 5—Imprecision in this subsection refers to twice the sample standard deviation of the thicknesses predicted by the sampling technique expressed as a percentage of the average measured thickness of all batts within the package.

10.5 *Thickness of Cut Roll*—An interlaboratory study of the cut roll sampling technique was run in 1995 on fibrous glass insulation. Five laboratories each tested three samples of two material thicknesses. The materials included an R-11 roll, 32 in. (9.75 m) long by 15 in. (38.1 cm) wide, and an R-19 roll, 39 ft (11.89 m) long by 15 in. (38.1 cm) wide. These materials represent the range of product packaged as rolls. The analyzed data consisted of a package average thickness, calculated from 25 sampling points per package, five locations each from five batts per each roll.

10.5.1 Precision Results:

	R-11	R-19
95 % repeatability limit (within laboratory)	25.9 %	6.7 %
95 % reproducibility limit (between laboratories)	38.7 %	11.4 %

10.5.2 *Bias*—There is not an accepted reference value available, and thickness bias cannot be determined.

10.6 *Density of Cut Roll*—Data from the interlaboratory study of the cut roll sampling technique was used to investigate the precision and bias of density calculations. Density is defined as the mass per unit volume, and is dependent upon both the process of weighing the sample and measuring its size in three dimensions.

10.6.1 Precision Results:

	R-11	R-19
95 % repeatability limit (within laboratory)	7.8 %	17.9 %
95 % reproducibility limit (between laboratories)	14.7 %	40.8 %

10.6.2 *Bias*—There is not an accepted reference value available, and density bias cannot be determined.

10.7 *Thickness of Full Roll*—An interlaboratory study of the full roll sampling technique was also run in 1995 on fibrous glass insulation. Four laboratories each tested three samples of

³ Supporting data have been filed at ASTM International Headquarters and may be obtained by requesting Research Report RR: C16 – 1016.

two material thicknesses. The materials included an R-10 roll, 100 ft (30.48 m) long by 72 in. (182.88 cm) wide, and an R-19 roll, 50 ft (15.24 m) long by 60 in. (152.4 cm) wide. These materials represent the range of product packaged as wider rolls. The analyzed data consisted of a package average thickness, calculated from 20 sampling points per package, ten locations each from two 15 ft (4.57 m) wide areas located 10 ft (3.05 m) from each package end.

10.7.1 Precision Results:

	R-10	R-19
95 % repeatability limit (within laboratory)	6.2 %	5.9 %
95 % reproducibility limit (between laboratories)	13.3 %	7.3 %

10.7.2 *Bias*—There is not an accepted reference value available, and thickness bias cannot be determined. The inter-laboratory study revealed a thickness deviation from cut roll insulation. The deviations are:

R-10	0.152 in. (-3.86 mm)
R-19	0.254 in. (-6.45 mm)

10.8 *Density of Full Roll*—Data from the interlaboratory study of the full roll sampling technique was used to investigate the precision and bias of density calculations. Density is defined as the mass per unit volume, and is dependent upon both the process of weighing the sample and measuring its size in three dimensions.

10.8.1 Precision Results:

	R-10	R-19
95 % repeatability limit (within laboratory)	8.7 %	6.5 %
95 % reproducibility limit (between laboratories)	13.3 %	7.2 %

10.8.2 *Bias*—There is not an accepted reference value available, and density bias cannot be determined.

10.9 The precision and bias for materials other than fibrous glass have not been determined.

11. Keywords

11.1 density-thermal insulating materials; thermal insulating materials—batt; thermal insulating materials—blanket; thickness—thermal insulating materials

ASTM International takes no position respecting the validity of any patent rights asserted in connection with any item mentioned in this standard. Users of this standard are expressly advised that determination of the validity of any such patent rights, and the risk of infringement of such rights, are entirely their own responsibility.

This standard is subject to revision at any time by the responsible technical committee and must be reviewed every five years and if not revised, either reapproved or withdrawn. Your comments are invited either for revision of this standard or for additional standards and should be addressed to ASTM International Headquarters. Your comments will receive careful consideration at a meeting of the responsible technical committee, which you may attend. If you feel that your comments have not received a fair hearing you should make your views known to the ASTM Committee on Standards, at the address shown below.

This standard is copyrighted by ASTM International, 100 Barr Harbor Drive, PO Box C700, West Conshohocken, PA 19428-2959, United States. Individual reprints (single or multiple copies) of this standard may be obtained by contacting ASTM at the above address or at 610-832-9585 (phone), 610-832-9555 (fax), or service@astm.org (e-mail); or through the ASTM website (www.astm.org).